

# LASER<sup>®</sup>

## Front Suspension Lower Arm Rear Bush Tool - for Land Rover

### Instructions



# Introduction

Developed to assist the removal and replacement of the rear bush on the front lower suspension arm fitted to Land Rover Discovery 3 and Range Rover Sport with the minimum of dismantling required.

Being able to perform this task on the vehicle saves considerable time over the more traditional use of a workshop press that requires the arm to be completely removed.

*NOTE: It has been noted during testing that the suspension bolts are often corroded into the centre of the bush, for this reason The Tool Connection recommend the use of a heat inductor type tool to heat up the bolt prior to removal to help break the rust that holds the bolt. (Laser Tool Part No. 5834)*

If possible one week prior to dismantling the vehicle, spray all bolts with penetrating oil to aid dismantling.

- OEM numbers covered by this tool:  
204-535/1, 204-535/2, 204-535/3, 204-535/4, 204-535/5.
- Designed to work with OEM Hydro bush RBX500291.
- Applications are for guidance only.

*N.B The information given below is for reference only.*

*The Tool Connection recommends the use of Manufacturer data or Autodata where relevant.*

# Components

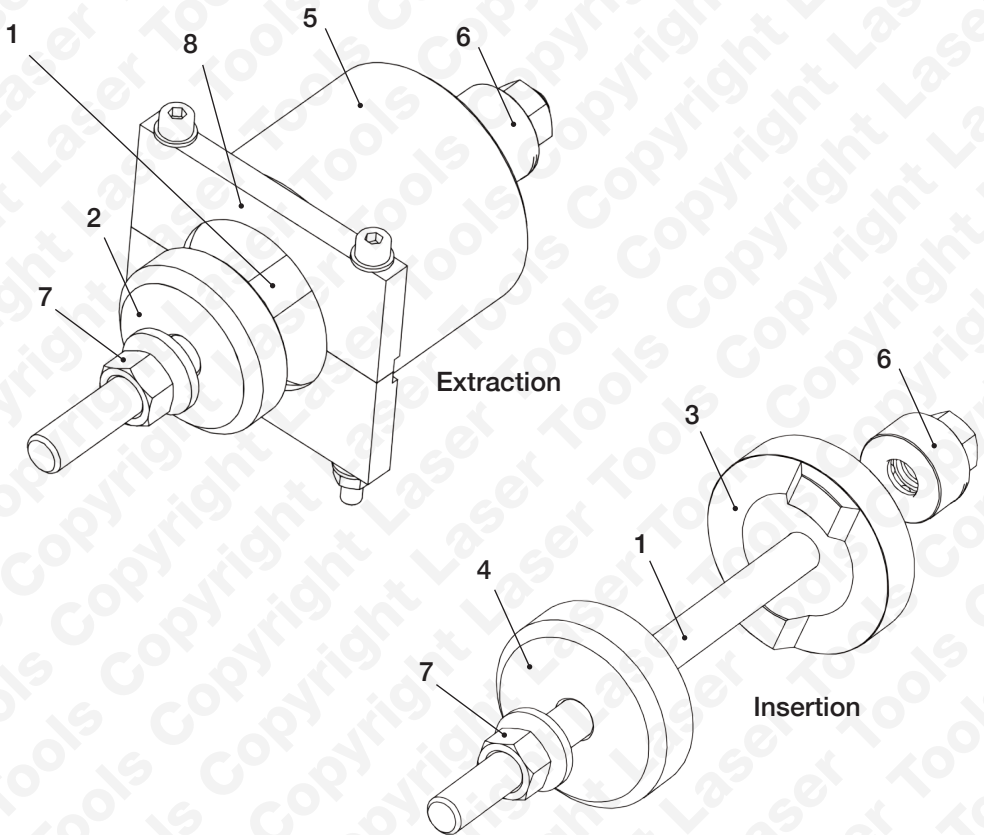

Ref.	OEM Ref	Description
1		Force Screw M16 x 1.5
2	204-535/2	Extractor Cup
3	204-535/3	Installation Plate
4	204-535/5	Installation Disc
5	204-535/1	Large Extractor Cup
6		Thrust Bearing
7		Nut
8	204-535/4	Clamshell Extractor Assembly

## **ALWAYS GREASE THE THREADED BAR**

Threaded bar and top plate are consumable and therefore not covered by The Tool Connection guarantee.

# Instructions

The following instructions are for guidance only. Please refer to OEM derived data such as the vehicles manufacturers own data or Autodata.

The use of this tool is purely down to the user's discretion and The Tool Connection Ltd. cannot be held responsible for any damage caused what so ever.

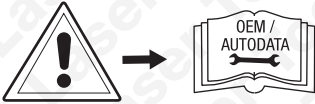

## Preparation:

**IMPORTANT: Ensure the force screw is well lubricated with molybdenum disulphide grease.**

- It is advised that any mounting bolts should be sprayed with penetrating oil prior to dismantling.
- Mount the vehicle on a ramp, wheels free.
- Clearly mark the bush bolt and its relative position to the chassis to assist assembly Fig 1.
- Remove relevant wheel.



## Instructions for Extraction:

- To aid removal of the relevant fixings ensure all components are well lubricated with penetrating oil and cleaned with a wire brush
- Remove the lower suspension damper bolt.
- Remove the rear bush bolt
- It is advised to remove the front bush bolt to make access easier
- Lower the arm to allow access as shown in Fig 2.
- Mark the bush to arm position with paint or similar
- Fit the Clamshell Extractor Plates as shown. Ensure the cut out on the clamshell pieces lines up with the weld line on the arm as shown in Fig 2 and Fig 3.

# Instructions

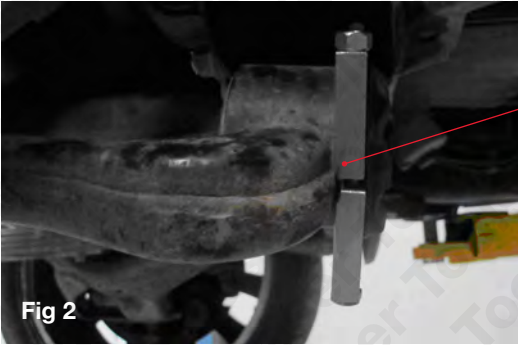

Align groove

Fig 2

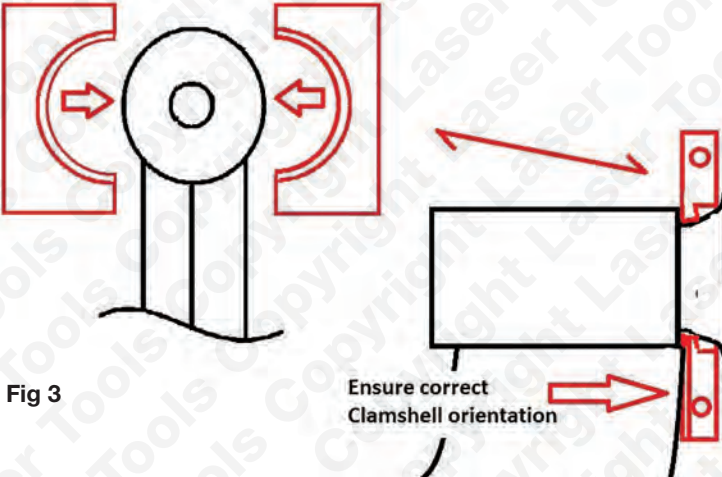

Fig 3

Ensure correct  
Clamshell orientation



Fig 4

- Assemble the rest of the extraction components as shown in Fig 4.
- Use plenty of Molybdenum Disulphide grease to lubricate the force screw.
- Ensure the assembly remains aligned through out extraction.

# Instructions

## Instructions for Insertion:

- Clean up arm and ensure all loose rust is removed from the area immediately around the bush eye.
- Line up the new bush as dictated by the positioning of the old bush.
- Assemble the installation components as shown in Fig 5.
- Ensure that the raised portions of the installation plate sit on the flat areas of the bush as shown.
- Ensure the force screw is well lubricated with Molybdenum Disulphide grease.

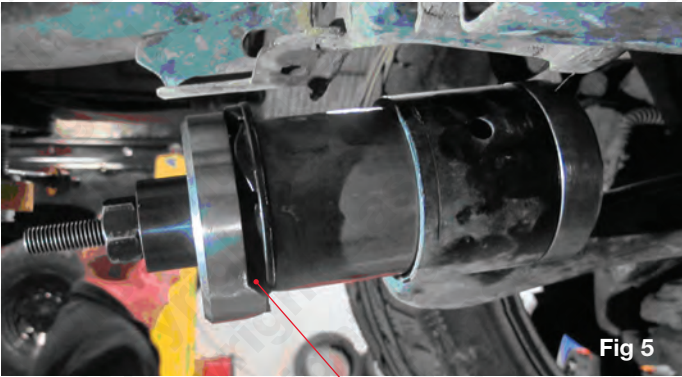

Align installation plate as shown

- Wind the load on to insert the bush, as the load comes on ensure the bush and cups remain correctly aligned.
- Continue winding the bush in until the bush stops.
- The bush end is not designed to sit flush against the arm eye. Designed to insert the bush to the correct depth.
- Reassemble the vehicle in reverse order but do not finally tighten the bush fixing bolts till the vehicle is back on its wheels to prevent unwanted bush “windup”.

### IMPORTANT:

**The bush has an eccentric fixing which is used to set the wheel alignment. for this reason after bush replacement the vehicles tracking and geometry should be checked and adjusted if required.**



Our products are designed to be used correctly and with care for the purpose for which they are intended. No liability is accepted by the Tool Connection for incorrect use of any of our products, and the Tool Connection cannot be held responsible for any damage to personnel, property or equipment when using the tools. Incorrect use will also invalidate the warranty.

If applicable, the applications database and any instructional information provided has been designed to offer general guidance for a particular tool's use and while all attention is given to the accuracy of the data no project should be attempted without referring first to the manufacturer's technical documentation (workshop or instruction manual) or the use of a recognised authority such as Autodata.

It is our policy to continually improve our products and thus we reserve the right to alter specifications and components without prior notice. It is the responsibility of the user to ensure the suitability of the tools and information prior to their use.



**Safety First. Be Protected.**



When you have finished with this product please recycle it

[www.lasertools.co.uk](http://www.lasertools.co.uk)

**Guarantee**



Distributed by The Tool Connection Ltd  
Kineton Road, Southam, Warwickshire CV47 0DR  
T +44 (0) 1926 815000 F +44 (0) 1926 815888  
[info@toolconnection.co.uk](mailto:info@toolconnection.co.uk) [www.toolconnection.co.uk](http://www.toolconnection.co.uk)

If this product fails through faulty materials or workmanship, contact our service department direct on: **+44 (0) 1926 818186**. Normal wear and tear are excluded as are consumable items and abuse.

6180\_Instructions\_v3

**[www.lasertools.co.uk](http://www.lasertools.co.uk)**